

HOFMANN



INSTALLATION and OPERATION MANUAL



duolift
DLA9012
9000 LB.
(ASYMMETRICAL)

READ and SAVE THIS INSTRUCTION MANUAL

HOFMANN 
USA

P.O. Box 600 • LaVergne, Tennessee 37086
(800) 251-4500 • (615) 641-1950
FAX (615) 641-3969
Internet: <http://www.hofmann-usa.com>

HOFMANN 
CANADA

P.O. Box 1270 • Belleville, Ontario K8N 5E9
(613) 962-9138 • FAX (613) 962-8302
Internet: <http://www.hofmann.ca>
E-mail: hofmann.ca@sympatico.ca

NOV 2003 6-2100

TABLE OF CONTENTS	PAGE
1 SAFETY AND OPERATING INSTRUCTIONS	1
2 SPECIFICATIONS.....	2
3 CONTENTS.....	3
4 INSTALLATION REQUIREMENTS AND TOOLS	3
5 INSTALLATION INSTRUCTIONS	4
5.1 UNPACKING PROCEDURE	4
5.2 BAY LAYOUT.....	5
5.3 SAFETY SHUT-OFF BAR INSTALLATION	5
5.4 SAFETY SHUT-OFF BAR ADJUSTMENT.....	6
5.5 TOWER POSITIONING AND SETUP	7
5.6 ROUTING OF EQUALIZATION CABLE.....	8
5.7 ARM INSTALLATION	9
5.8 ARM RESTRAINT INSTALLATION	10
5.9 SAFETY RELEASE CABLE ROUTING AND ADJUSTMENT.....	11
5.10 POWER PACK INSTALLATION.....	12
5.11 HYDRAULIC SYSTEM INSTALLATION	13
5.12 HYDRAULIC SYSTEM BLEEDING	14
5.13 TOWER POSITIONING AND ANCHORING	15
5.14 SHIMMING OF THE REMAINING TOWER.....	16
6 PERIODIC MAINTENANCE.....	17
7 SAFETY AWARENESS	18
8 PARTS MANUAL	19
8.1 LIFT ASSEMBLY	19
8.2 LIFT ASSEMBLY PARTS LIST.....	20
8.3 HYDRAULIC SYSTEM	22
8.4 HYDRAULIC SYSTEM PARTS LIST	23
8.5 POWER PACK: #6-2055 (AB-1381) 208-230V/1PH/60Hz	24
8.6 POWER PACK PARTS LIST: #6-2055 (AB-1381) 208-230V/1PH/60Hz.....	25
8.7 LIFT MAINTENANCE GUIDELINES – CABLE EQUALIZATION	26

1 SAFETY AND OPERATING INSTRUCTIONS

1. When using this lift, basic safety precautions should always be followed, including the following.
2. Read all instructions in this manual and on the lift.
3. Inspect lift daily. Do not operate if it malfunctions or problems have been encountered.
4. Never attempt to overload the lift. The manufacturer's rated capacity is shown on the identification label on the power side column. Do not override the operating controls or the warranty will be void.
5. Before driving vehicle between the towers, position the arms to the drive-through position to ensure unobstructed clearance. Do not hit or run over arms as this could damage the lift and/or vehicle.
6. Only trained and authorized personnel should operate the lift. Do not allow customers or bystanders to operate the lift or be in the lift area.
7. Position the lift support pads to contact the vehicle manufacturers recommended lifting points. Raise the lift until the pads contact the vehicle. Check pads for secure contact with the vehicle. Check all arm restraints and insure they are properly engaged. Raise the lift to the desired working height.
8. Some pickup trucks may require an optional truck adapter to clear running boards or other accessories.
NOTE: Always use all 4 arms to raise and support vehicle.
9. **Caution! Never work under the lift unless the mechanical safety locks are engaged.**
10. Note that the removal or installation of some vehicle parts may cause a critical load shift in the center of gravity and may cause the vehicle to become unstable. Refer to the vehicle manufacturer's service manual for recommended procedures.
11. Always keep the lift area free of obstruction and debris. Grease and oil spills should always be cleaned up immediately.
12. Never raise vehicle with passengers inside.
13. Before lowering check area for any obstructions.
14. Before removing the vehicle from the lift area, position the arms to the drive-through position to prevent damage to the lift and /or vehicle.

2 SPECIFICATIONS

Capacity:
 Overall Width:
 Width Between Columns:
 Drive-Thru Width:
 Overall Height:
 Under Bar Clearance:
 Height to Lowered Lift Pads:
 Height to Raised Low Lift Pad:
 Height to Raised Low Lift Pad:
 Front Arm Retracted Length:
 Front Arm Extended Length:
 Rear Arm Retracted Length:
 Rear Arm Extended Length:
 Maximum Lifting Height:
 Lift Time:
 Power Requirements (Standard):

9000 lbs.	4082 kg
137"	3480 mm
107"	2717 mm
87"	2210 mm
144"	3658 mm
140"	3556 mm
4 3/4"	121 mm
6 1/4"	159 mm
9 1/4"	235 mm
27"	686 mm
40"	1016 mm
37 1/2"	953 mm
59 1/2"	1511 mm
78"	1981 mm
45 seconds	
230 Volts AC, 1 Ph., 60Hz.	

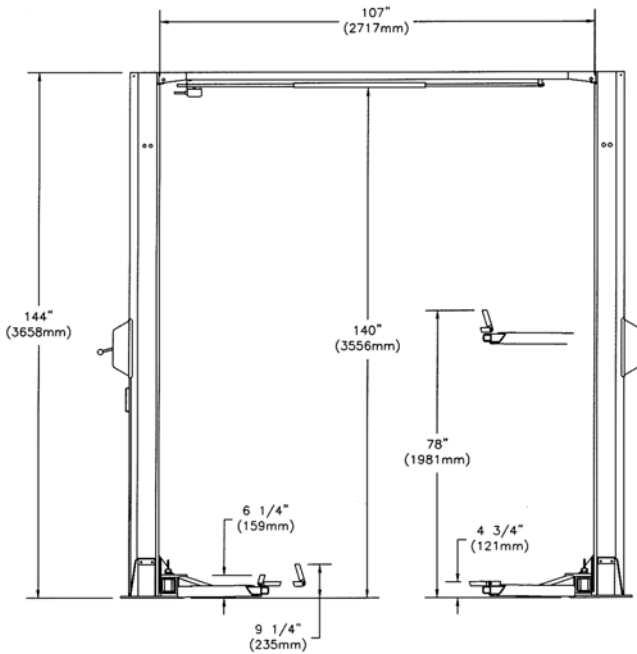

Figure 1 – Front View

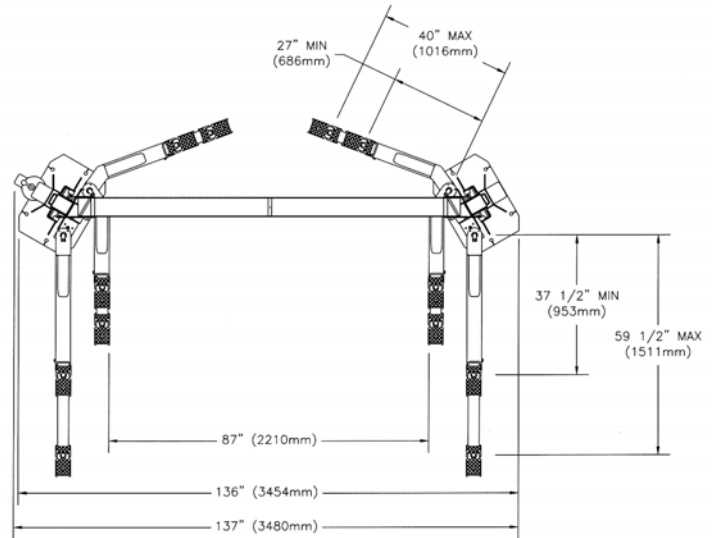

Figure 2 – Top View

3 CONTENTS

The complete lift is contained in two (2) packages:

1. The **main structural components** are packed in a steel frame.
2. The remaining parts are packed in an **accessory box**.

Main Structural Components includes:

- 1pc. - Power side tower and carriage assembly
- 1pc. - Slave side tower and carriage assembly
- 1pc. - Crossmember
- 1pc. - Actuator Bar w/ foam

Accessory box contents:

- 4pcs. - Locking Arm Assembly w/arm pins
- 2pcs. - Safety Covers w/Decals
- 1pc. - Hardware Package w/Packing List
- 1pc. - Actuator Extension
- 1pc. - Actuator Mounting Bracket
- 1pc. - Power Pack
- 4pc. - Arm Restraint
- 1pc. - Safety Release Cable
- 1pc. - Hydraulic Hose (Long)
- 1pc. - Hydraulic Hose (Short)
- 2pcs. - Equalizing Cable w/Hex Nuts
- 1pc. - ALI manual “Lifting It Right”
- 1pc. - Automotive Lift Safety Tips
- 1pc. - Automotive Lift, Operation, Inspection and Maintenance manual
- 1pc. - “ALI” Quick Reference Guide
- 1pc. - Owner’s manual
- 1pc. - Safety Shut-off Microswitch Assembly (Components)

4 INSTALLATION REQUIREMENTS AND TOOLS

IMPORTANT: It is the user’s responsibility to provide a satisfactory installation area for the lift. Lifts should only be installed on level concrete floors with a minimum thickness of five (5) inches or 130 mm. Concrete must have a minimum strength of 4000 psi or 30 MPa and should be aged thirty (30) days prior to installation. Please consult the architect, contractor or engineer if doubt exists as to the strength and feasibility of the floor to enable proper lift installation and operation.

It is the user’s responsibility to provide all wiring for electrical hook-up prior to installation and to insure that the electrical installation conforms to local building codes. Where required, it is the user’s responsibility to provide an electrical isolation switch located in close proximity to the lift that will enable emergency stop capability and isolate electrical power from the lift for any servicing requirements.

Tools Required:

- a. 16ft. Measuring Tape
- b. Chalk Line
- c. Rotary Hammer Drill
- d. 3/4" diameter Masonry Drill Bit
- e. Hammer
- f. SAE Wrenches and Ratchet Set
- g. 2ft. Level
- h. 4ft. Level
- i. Crow Bar
- j. 12ft. Step Ladder
- k. Side Cutters
- l. Screwdrivers
- m. 4" x 4" Wooden Blocks (for unpacking)

5 INSTALLATION INSTRUCTIONS

When the lift arrives on site:

- Read the owner's manual and make sure the installation instructions are fully understood.
- Check for any freight damages.
- Check the contents of the accessory and hardware boxes to make sure no parts are missing.
- Gather all the tools listed above.

5.1 UNPACKING PROCEDURE

1. **Important!** Place the main structural components on wooden blocks so that the steel shipping frames can be removed.
2. Remove the plastic wrapping.
3. Remove the crossmember, and the actuator bar.
4. Unbolt the steel shipping frames.
5. Lay each tower on the floor with the carriage side up.
6. Check the installation area for obstructions. (Lights, Heating Ducts, Ceiling, Floor Drains, etc.)
7. Prepare the bay by selecting the location of the lift relative to the walls. Clear the installation area of all packaging materials to avoid trip hazards. Draw a chalk line on the floor to represent the centerline of the bay then draw a second chalk line at 90° for locating the lift towers. Refer to **Figure 3**.

5.2 BAY LAYOUT

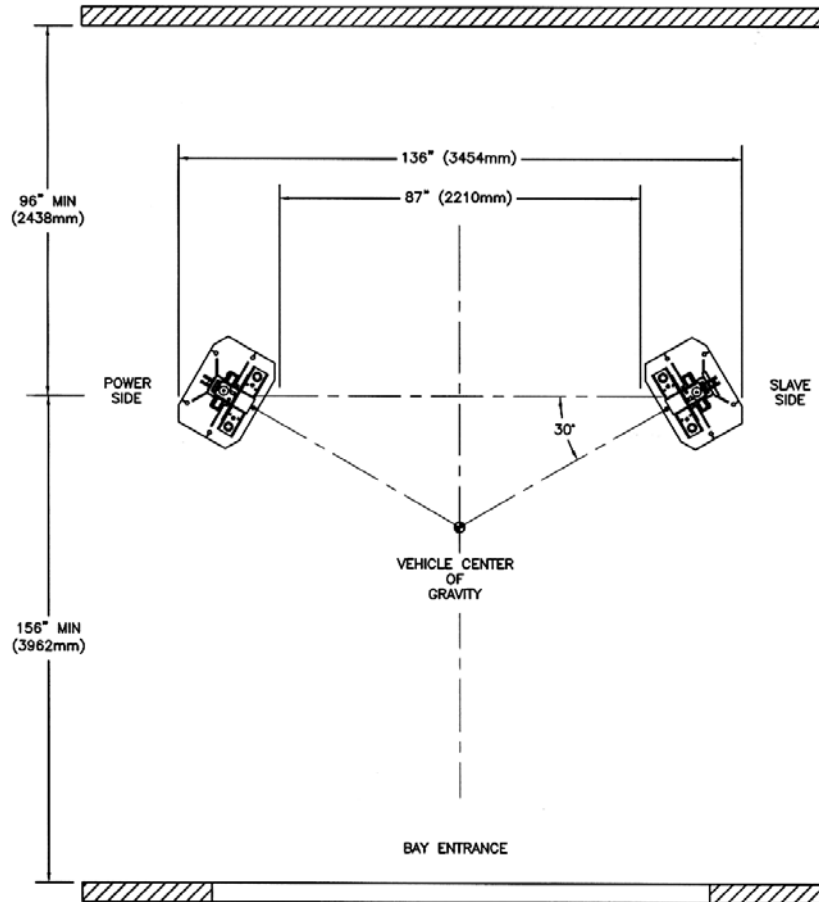

Figure 3 – Bay Layout

5.3 SAFETY SHUT-OFF BAR INSTALLATION

Note: The safety shut off will disconnect the power to the power pack when an obstruction touches the padded bar or the carriages reach their maximum height. The safety shut off switch is factory pre-wired. Refer to Figure 4.

Note: This procedure can be done on the floor.

1. Attach the Actuator Mounting Bracket (1-1378) to the crossmember using one ¼" NC x ¾" lg. hex head bolt (6-0178), one ¼" ID lockwasher (6-0056), and one ¼" NC hex nut (6-0032).
2. Attach the Actuator Bar to the Actuator Mounting Bracket using one ¼" NC x 1 ½" lg. hex head bolt (6-0205), one ¼" ID lockwasher (6-0056), and one ¼" NC hex nut (6-0032).
3. Slide Safety Shut-Off Microswitch Assembly over the open end of actuator bar and bolt the assembly to the crossmember using two (2) ¼" NC x ¾" lg. hex head bolts (6-0178), two (2) ¼" ID lockwashers (6-0056), and two (2) ¼" NC hex nut (6-0032).

4. Install the 1/4" NC x 2" lg. hex bolt (6-0741) into the actuator extension (1-1379) then attach the 1/4" NC hex nut (6-0032) from the other side to hold the bolt in place.

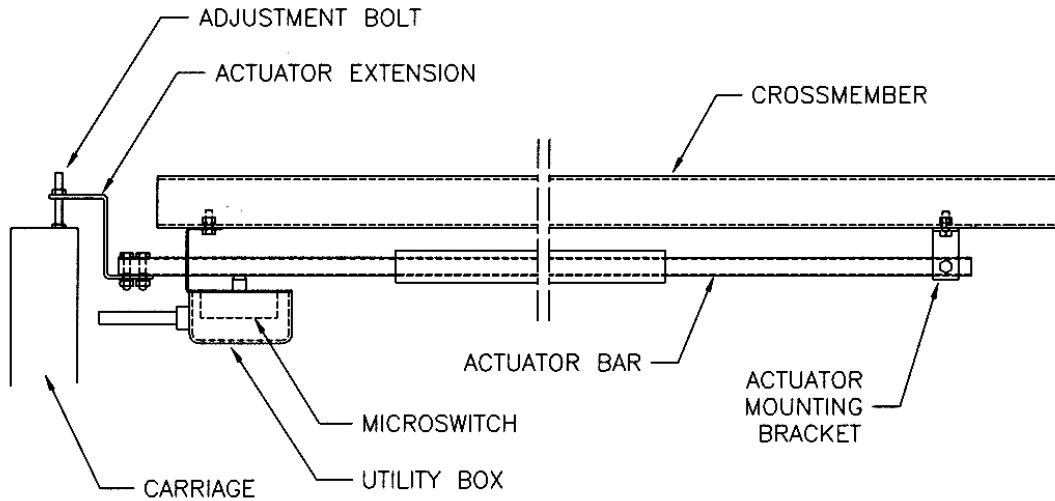

Figure 4 – Safety Shut-Off Bar Installation

5.4 SAFETY SHUT-OFF BAR ADJUSTMENT

Note: This procedure must be done last. Refer to Figure 4.

1. When the lift is fully installed, leveled and operational, extend the carriages to their full upper limit.
2. Lower the carriages about 1/4" to 1/2".
3. Bolt the Actuator Extension onto the open end of actuator bar using two (2) 1/4" NC x 1 1/4" lg. hex head bolts (6-0027), two (2) 1/4" ID lockwashers (6-0056), and two (2) 1/4" NC hex nuts (6-0032).
4. Adjust the 1/4" NC x 2" lg. hex bolt so that the end of the bolt is in contact with the carriage. Tighten the 1/4" NC hex nut on the bolt.

5.5 TOWER POSITIONING AND SETUP

1. Locate the power side and slave side towers and position them as shown in **Figure 3**. Double check all the dimensions in the layout.
2. Using a stepladder, install the crossmember using eight (8) ½"-16UNC x 1 ¼" lg. hex head bolts, eight (8) ½" ID lock washers, eight (8) ½" hex nuts and eight (8) ½" flat washers. See **Figure 5**
3. Check the towers to make sure they are located, and positioned in the correct location. Refer to **Figure 3**.

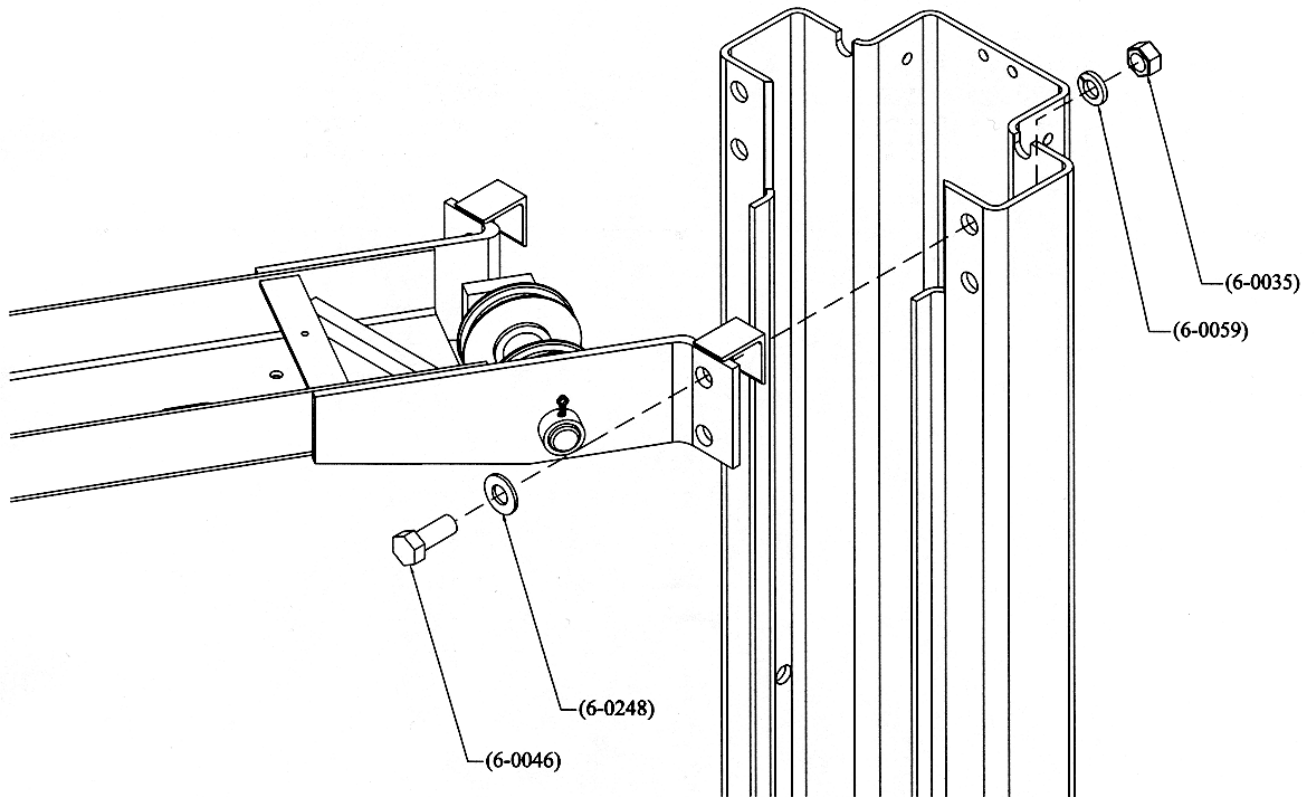

Figure 5 – Crossmember Assembly

5.6 ROUTING OF EQUALIZATION CABLE

1. Manually lift the carriages to the first safety latch.
2. Remove equalizing cables from the accessory kit box, and then locate the (8) ½”-13UNC nuts from a polybag in the hardware kit box.
3. Equalizing cables are to be routed as shown in **Fig. 6a**. Using the first cable, insert the short threaded stud through the 9/16” dia. hole at the bottom of the carriage, and feed upwards until the stud comes through the top of the carriage. Place a ½”-13UNC nut at the center of the stud, and then **firmly tighten** a second nut up against it using two wrenches. Pull the cable back down through the bottom of the carriage. (**Fig. 6b - cross-sectional view of bottom of carriage**).
4. At the bottom of the column, remove the hitch pin, pulley pin and pulley from the baseplate (**Fig. 6c**). Route equalizing cable around pulley and reassemble the pulley to the baseplate. **IMPORTANT – Hitch pin must be installed securely**. Then route the cable up through the carriage, around the pulley at the top of the column, across the crossmember, around the pulley at the top of the other column and then down (**Fig 6a**). Insert the threaded stud into the 9/16” Dia. hole in the top of the other carriage.

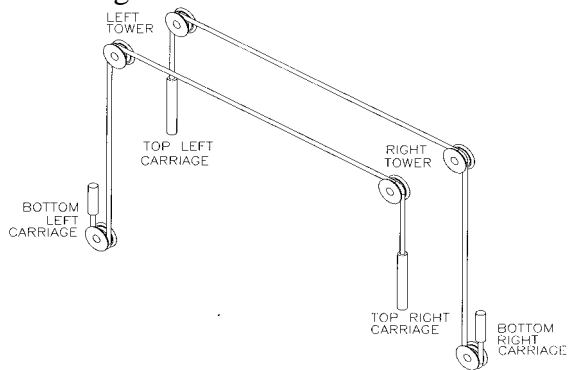

Figure 6a

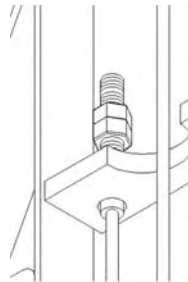

Figure 6b

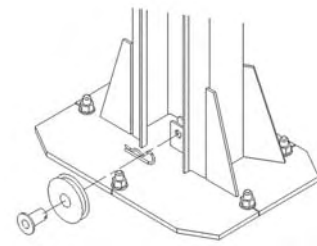

Figure 6c

5. Use a wrench to hold the top of the threaded stud to prevent it from rotating. Hand tighten (2) ½”-13 UNC nuts onto the threaded stud enough to remove all visible cable slack (**Step A**). Repeat steps 2 to 5 for the other equalizing cable.
6. Using a wrench to hold the top of the threaded stud, to prevent it from rotating, tighten the first nut approximately 1 ½” (**Step B**) past the hand tightened position. Then **firmly tighten** the second nut against the first one to lock it in place (**Step C**). Repeat for the other cable.

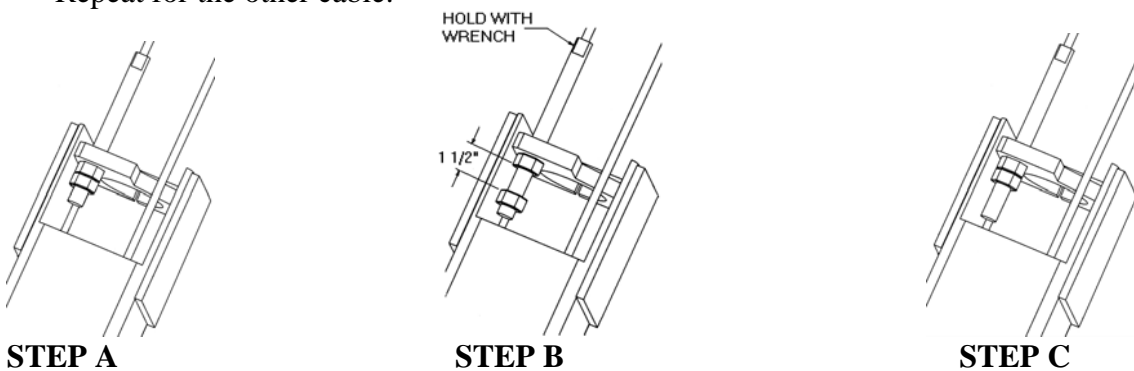
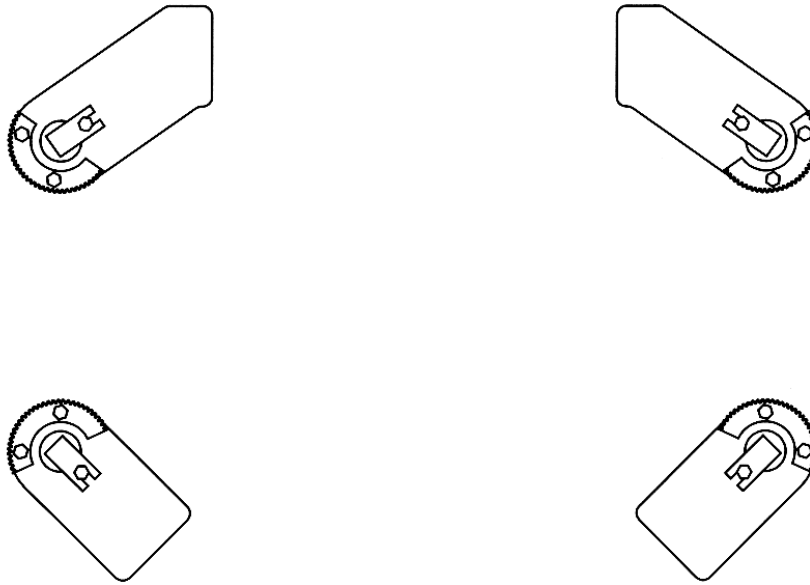

Figure 6

5.7 ARM INSTALLATION

1. Remove the four (4) 5/16"-18UNC x 3/4"LG. hex head bolts that are holding the arm pins to the arm. Install the arms on the carriages.
2. Grease and insert arm pins. Align the notch on each arm pin with the tapped hole on the arm, and using the 5/16"-18UNC x 3/4"LG. hex head bolt removed in previous step, reinstall and tighten securely.
3. Using two (2) 5/16"-18UNC x 1 1/4" LG. hex head bolts and two (2) 5/16" flatwashers, attach each arm restraint gear as shown in **Figure 6**.

FRONT



REAR

Figure 6 – Arm Installation

5.8 ARM RESTRAINT INSTALLATION

Using two (2) 3/8"-16UNC x 1" LG. socket head cap screws, and two (2) 3/8" ID lockwashers, install the arm restraint assemblies as shown in **Figure 7**. Before tightening completely, make sure that the arm restraint has full contact with the arm restraint gear by pushing it firmly against the arm.

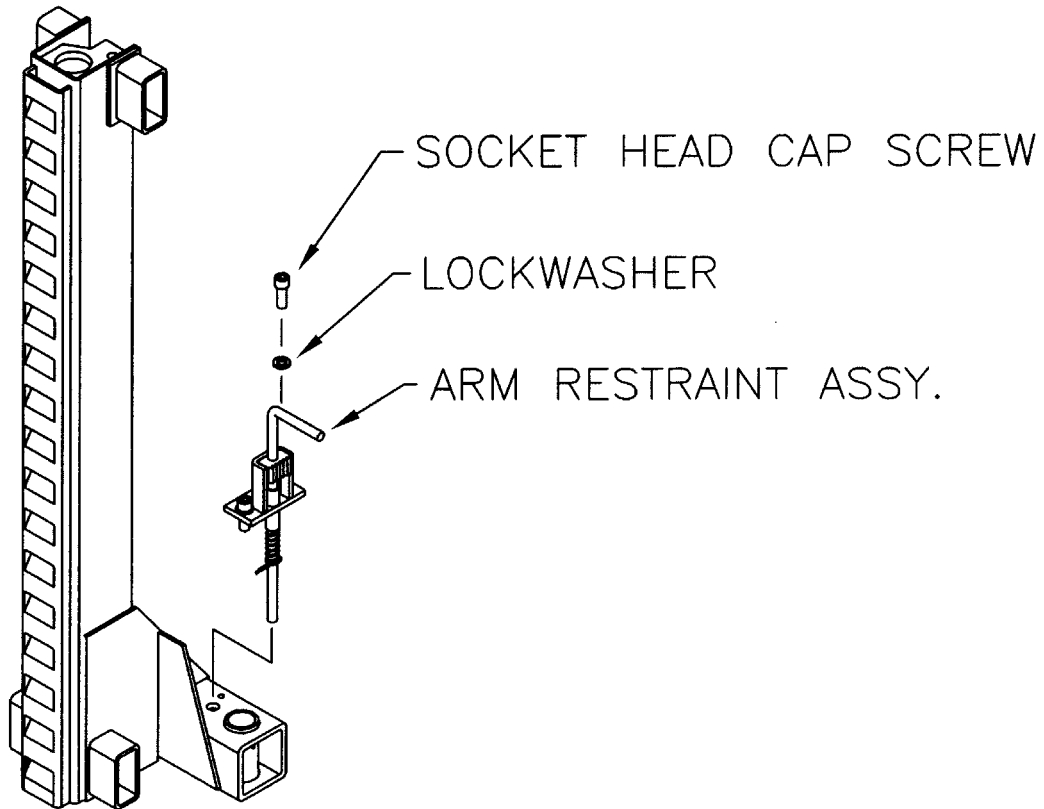

Figure 7 – Arm Restraint Installation

5.9 SAFETY RELEASE CABLE ROUTING AND ADJUSTMENT

The mechanical safety automatically engages. To release the mechanical safety, you must first raise the lift approximately 2", then pull the safety release lever down. This disengages the power side safety dog and activates the safety cable to release the slave side safety dog.

1. Install the safety release bracket on each tower as shown in **Figure 8**. Attach the safety pulley to the bracket using the 3/8" x 5/8" LG. shoulder bolt, 5/16" lockwasher and 5/16" hex nut. Attach the pulley bracket, complete with pulley, to the tower using the 5/16" x 3/4" LG. hex bolt, 5/16" flat washer, 5/16" lockwasher, and 5/16" hex nut.

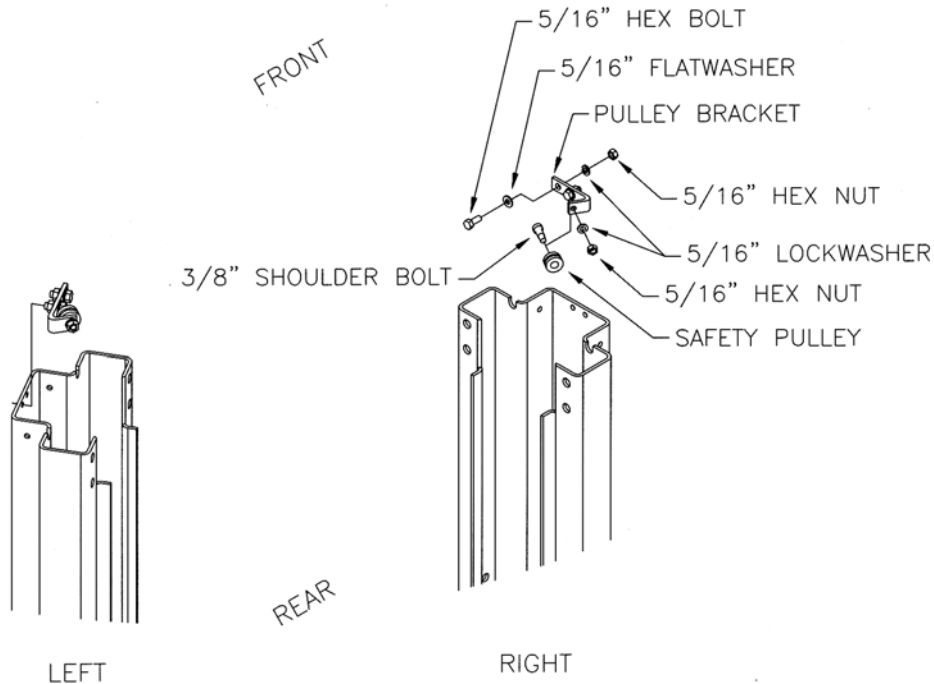

Figure 8 – Safety Release Cable Bracket

2. Refer to **Figure 9** for safety release cable routing. The end of the cable that has a collar attaches to the slave side tower. The free end is fixed to the power side tower using two (2) wire rope clips.
3. Install the safety release handle onto the power side safety dog. Lock the safety dog into position using one 1/2"-13UNC hex nut.
4. Start routing the safety release cable from the slave side of crossmember. Feed the cable over the small pulley, then guide the cable down along the inside of the slave side tower. Pull the cable out through the opening in the back of the tower near the safety dog.
5. Guide the cable up under the large pulley towards the end of the safety dog. Remove the 3/8" x 1 1/2" shoulder bolt from the safety dog. Feed the shoulder bolt through the collar of the safety release cable and then replace the shoulder bolt securely to the safety dog. **NOTE:** Make sure shoulder bolt, 3/8" dia. x 1 1/2" lg. (6-0801), is lock tight to safety dog.

6. Repeat step 2 for the power side tower.
7. Guide the cable up under the large pulley and then over the small pulley towards the safety dog as shown in Figure 9. Wrap the cable around the thimble (attached to the safety dog with a 5/16" x 1/2" lg. shoulder bolt) and then clamp it using two (2) wire rope clips. Do not tighten fully at this stage.
8. Adjust the cable length so that both safety dogs travel from full engagement position to full release position when the safety release handle is pulled. **Tighten both wire rope clips firmly when adjustment is completed.**

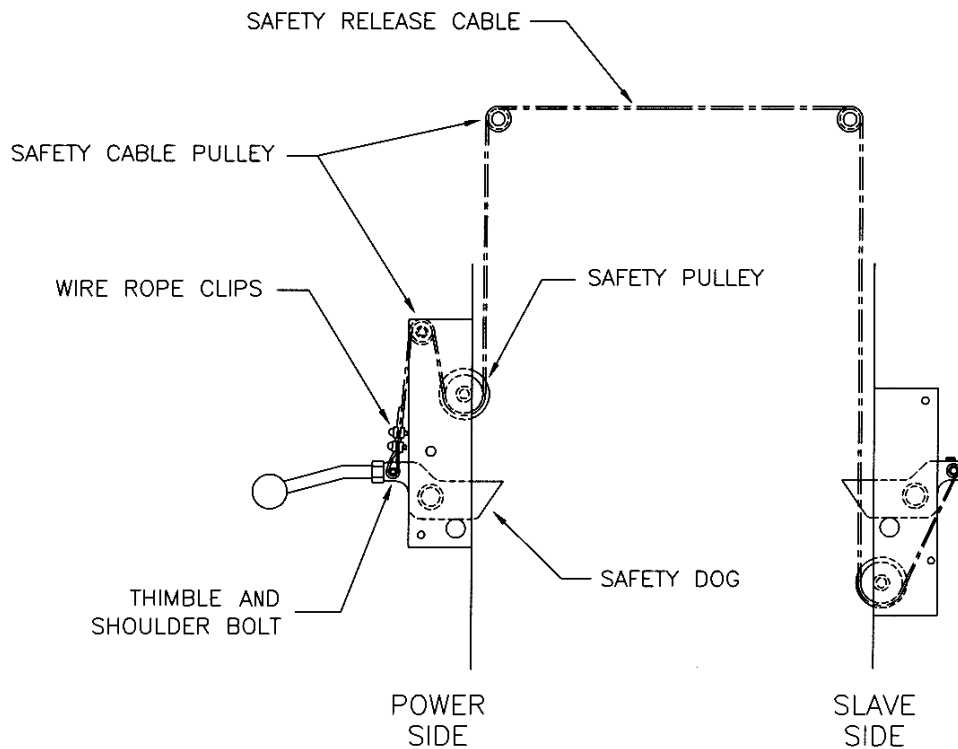

Figure 9 – Safety Release Routing and Adjustment

5.10 POWER PACK INSTALLATION

1. Remove the **red** plastic cap located at the rear of the power pack, and install the "T" fitting located in the hardware kit.
2. Bolt power pack to the mounting bracket on the power side tower using four (4) 5/16"-18UNC x 1"LG. hex head bolts, four (4) 5/16" ID lock washers, four (4) 5/16" ID flat washers and four (4) 5/16"-18UNC hex nuts. Do not tighten.
3. Remove the filler cap from the powerpack and fill the reservoir with approximately 4.5 Gal. (18L) of ISO32 hydraulic oil (10 wt. hydraulic oil). Remove breather screw when filling and replace when full.
4. A **certified electrician** must connect the 230Volt/1Ph power to the motor. The electrical diagram is provided, refer to **Figure 11**.

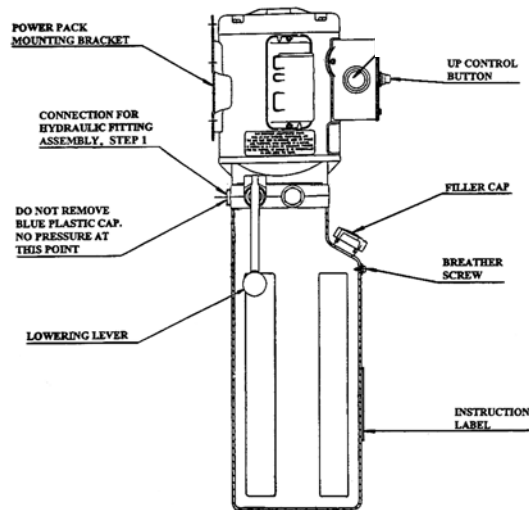

Figure 10 – Powerpack Details

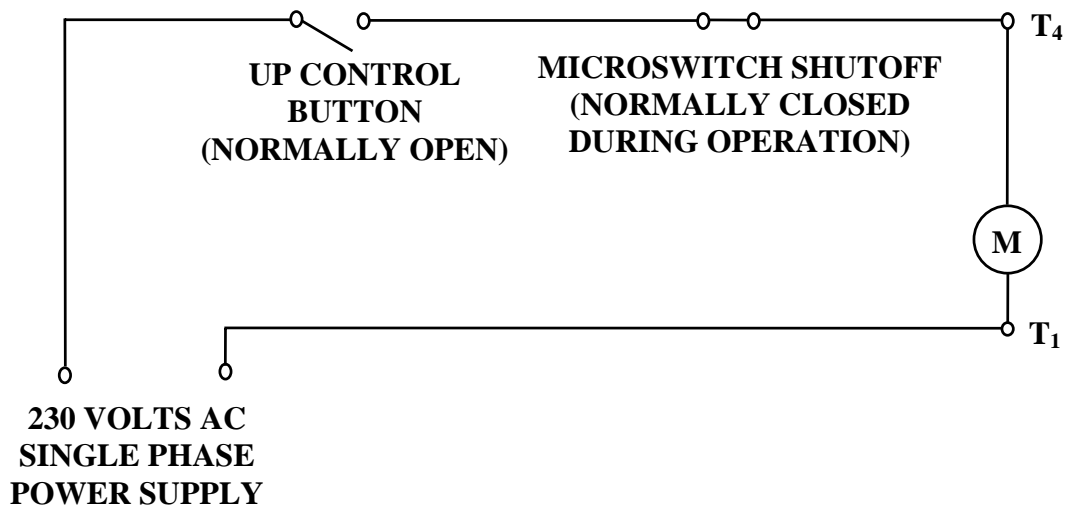

Figure 11 – Electrical Diagram

5.11 HYDRAULIC SYSTEM INSTALLATION

REFER TO HYDRAULIC PARTS LIST

1. Connect the 45° end of the long hose to the “T” fitting on the powerpack.
2. Connect the 45° end of the short hose to the other end of the “T” fitting.
3. Remove the plastic cap from the bottom of the power side cylinder and connect the 90° end of the short hose to the cylinder.
4. Loop the hydraulic hose up the power side tower, across the overhead and down the slave side tower. Place rubber grommets (item 68 in the lift assembly) between the tower and the hose at the top of each tower.

5. Remove the plastic cap from the bottom of the slave side cylinder and connect the 90° end of the long hose to the cylinder.
6. The long hydraulic hose must be fixed to the towers using six (6) hose clamps. Screw the hose clamps into the weld nuts on the towers using 1/4"-20UNC x 3/8"lg. round head screws.
7. The long hydraulic hose must be fixed to the crossmember using two (2) hose clamps. Screw the hose clamps into the crossmember using #10 x 3/8" lg. self threading screws.

5.12 HYDRAULIC SYSTEM BLEEDING

1. Crack the caps located at the top of both cylinders.
2. Power up 2"-3". You should hear air escaping around the caps. Repeat 3 - 4 times or until only oil is coming out of the caps.
3. Tighten the caps and lower the lift.

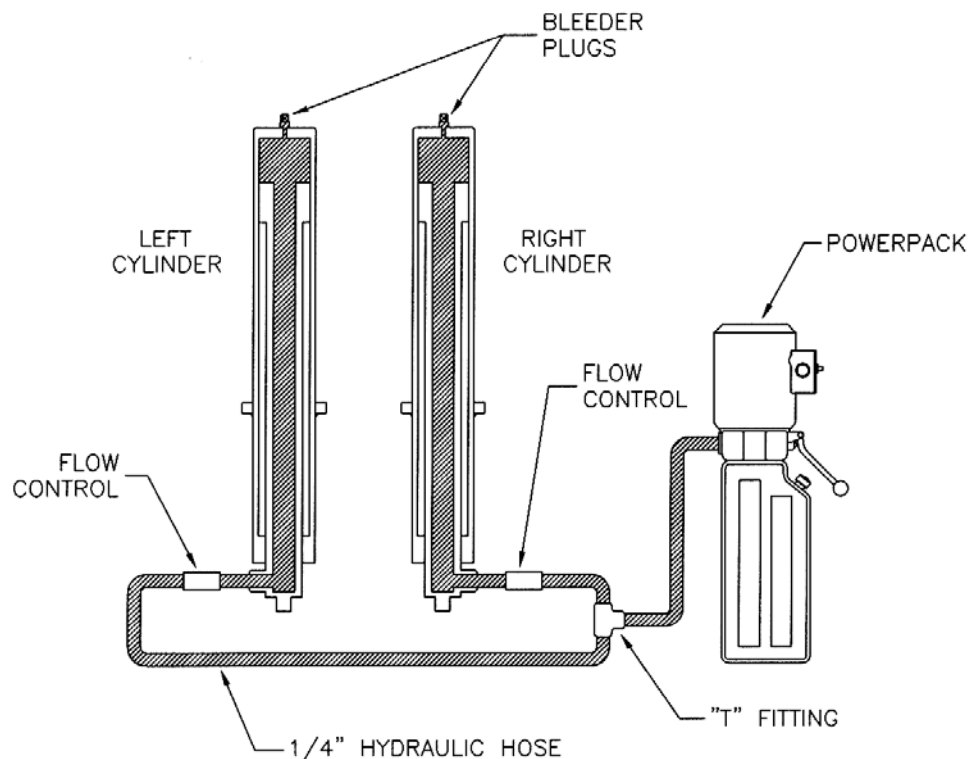

Figure 12 – Hydraulic Schematic

5.13 TOWER POSITIONING AND ANCHORING

WARNING! Failure to follow these instructions may cause an unsafe operating condition.

WARNING! Before proceeding with installation, review Section 4: Installation & Tools.

- Using a 4ft. level on top of the crossmember, determine which column is higher. Refer to **Figure 13**.
- Using a 2ft. level on the sides of the high column, ensure that the column is level in the vertical position (**Figure 14**). Use shims under the column baseplate to hold the column level. Ensure that the base plate is completely supported by shims where it does not contact the floor (**Figure 15**).

WARNING! Do not use more than 1/2" (13mm) of shims. Anchor bolts supplied allow for a maximum of 1/2" (13mm) of shim. If more than 1/2" (13mm) of shims are required, **DO NOT** proceed with installation and contact Product Manufacturer / Supplier for further details.

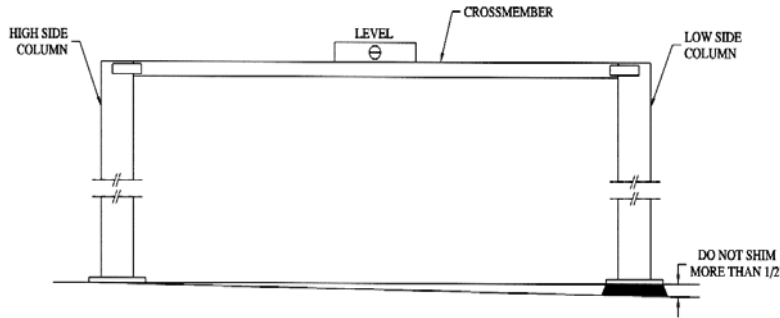

Figure 13

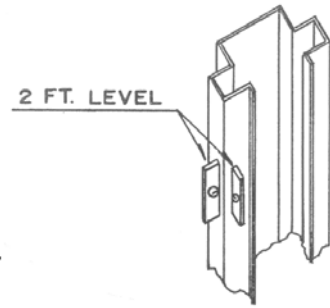

Figure 14

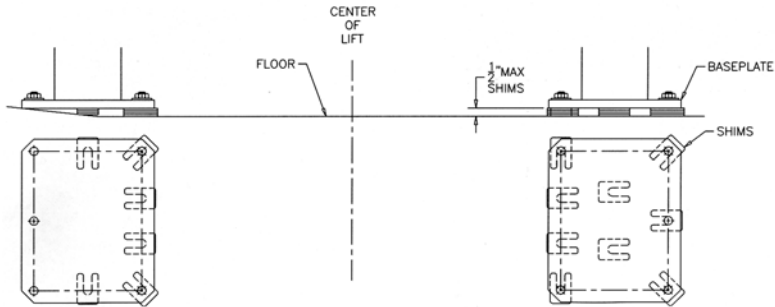

Figure 15 - Shims

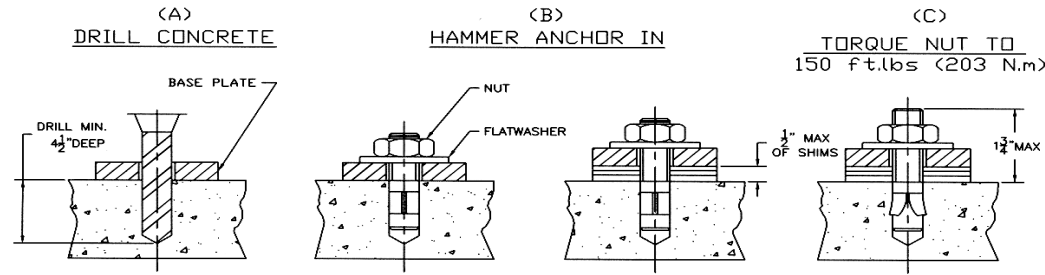

Figure 16 – Anchor Bolts

3. Refer to Bay Layout (**Figure 3**) to ensure that the column is still in the proper position. Using a rotary hammer drill with a 3/4" masonry drill bit, drill holes in the floor on the high side column using the tower baseplate as a template. Make sure that the 3/4" masonry drill is in good condition (**Figure 16**).
4. Carefully clean out drilling dust from the anchor holes. Hammer in the anchor bolts (**Figure 16**). Hand tighten all anchor bolts.
5. Reconfirm that the column is level front to rear and side to side (**Figure 14**). Add or remove shims as required.
6. Torque all anchor bolts to 150 ft-lbs. (203 Nm), continually checking that the column is level as you proceed. If anchor bolts do not tighten to 150 ft-lbs. OR project more than 1 3/4" above the concrete surface (**Figure 16**), the concrete MUST be replaced by an appropriate concrete pad. (*Consult Product Manufacturer / Supplier for further details*).

5.14 SHIMMING OF THE REMAINING TOWER

1. Using a 4ft. level on top of the crossmember (**Figure 13**) and a 2ft. level on the low side column (**Figure 14**), shim underneath the baseplate until the crossmember and column are level. Ensure that the baseplate is completely supported by shims where it does not contact the floor (**Figure 15**).

WARNING! *Do not use more than 1/2" (13mm) of shims. Anchor bolts supplied allow for a maximum of 1/2" (13mm) of shim. If more than 1/2" (13mm) of shims are required, **DO NOT** proceed with installation and contact Product Manufacturer / Supplier for further details.*









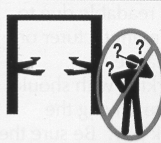

2. Refer to Bay Layout (**Figure 3**) to ensure that the column is still in the proper position. Using a rotary hammer drill with a 3/4" masonry drill bit, drill holes in the floor on the low side column using the tower baseplate as a template. Make sure that the 3/4" masonry drill is in good condition (**Figure 16**).
3. Carefully clean out drilling dust from the anchor holes. Hammer in the anchor bolts (**Figure 16**). Hand tighten all anchor bolts.
4. Reconfirm that the column is level front to rear and side to side (**Figure 14**). Add or remove shims as required.
5. Torque all anchor bolts to 150 ft-lbs. (203 Nm), continually checking that the crossmember and column are level as you proceed. If anchor bolts do not tighten to 150 ft-lbs. OR project more than 1 3/4" above the concrete surface (**Figure 16**), the concrete MUST be replaced by an appropriate concrete pad. (*Consult Product Manufacturer / Supplier for further details*).
6. Verify that the entire lift is level both horizontally and vertically to ensure optimum lifting performance. **NOTE: Perform a monthly inspection and torque all anchor bolts to 150 ft-lbs. (203 Nm).**

6 PERIODIC MAINTENANCE

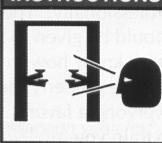
1. Inspect lift daily, to assure the mechanical safety is operating properly.
2. Check the telescopic arms for movement. Clean any grease or oil from the lifting adapters.
3. Raise and lower the lift at the beginning of each shift, without a vehicle on, to verify the lift is leveled and operating properly. Perform hydraulic leveling procedure when the lift is out of level.
4. Lubricate safety dog mechanisms with penetrating oil monthly.
5. Grease arm pins supports monthly.
6. Check hydraulic fittings for tightness.
7. Annual lift inspection as per Automotive Lift Operation, Inspection and Maintenance (ALOIM).
8. Apply a small amount of grease to glide bearing tracks periodically.
9. Check lift for synchronization periodically.
10. Check bolts on carriage stops for tightness
11. Change hydraulic oil every two years.

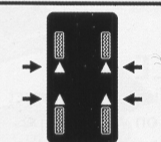
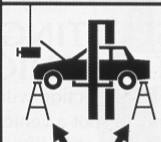
NOTE: If you are unclear call your local representative immediately.

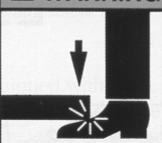
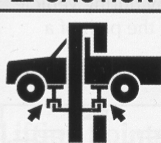
7 SAFETY AWARENESS
- AUTOMOTIVE LIFT INSTITUTE (ALI)

<p>⚠ WARNING</p>  <p>Clear area if vehicle is in danger of falling.</p>	<p>⚠ WARNING</p>  <p>Position vehicle with center of gravity midway between adapters.</p>	<p>⚠ CAUTION</p>  <p>Lift to be used by trained operator only.</p>	<p>⚠ CAUTION</p>  <p>Authorized personnel only in lift area.</p>	<p>SAFETY INSTRUCTIONS</p>  <p>Read operating and safety manuals before using lift.</p>	<p>SAFETY INSTRUCTIONS</p>  <p>Proper maintenance and inspection is necessary for safe operation.</p>
<p>⚠ WARNING</p>  <p>Remain clear of lift when raising or lowering vehicle.</p>	<p>⚠ WARNING</p>  <p>Avoid excessive rocking of vehicle while on lift.</p>	<p>⚠ CAUTION</p>  <p>Use vehicle manufacturer's lift points.</p>	<p>⚠ CAUTION</p>  <p>Always use safety stands when removing or installing heavy components.</p>	<p>SAFETY INSTRUCTIONS</p>  <p>Do not operate a damaged lift.</p> <p>The messages and pictographs shown are generic in nature and are meant to generally represent hazards common to all automotive lifts regardless of specific style.</p> <p>Funding for the development and validation of these labels was provided by the Automotive Lift Institute, P.O. Box 33116, Indialantic, FL 32903-3116. They are protected by copyright. Set of labels may be obtained from ALI or its member companies.</p> <p>© 1992 by ALI, Inc. ALIWL1916</p>	
<p>⚠ WARNING</p>  <p>Do not override self-closing lift controls.</p>	<p>⚠ WARNING</p>  <p>Keep feet clear of lift while lowering.</p>	<p>⚠ CAUTION</p>  <p>Use height extenders when necessary to ensure good contact.</p>	<p>⚠ CAUTION</p>  <p>Auxiliary adapters may reduce load capacity.</p>	<p><i>Warning Labels for 2-post surface mounted lifts. Daily review of these Safety Messages and Warnings is suggested.</i></p>	

8 PARTS MANUAL

8.1 LIFT ASSEMBLY

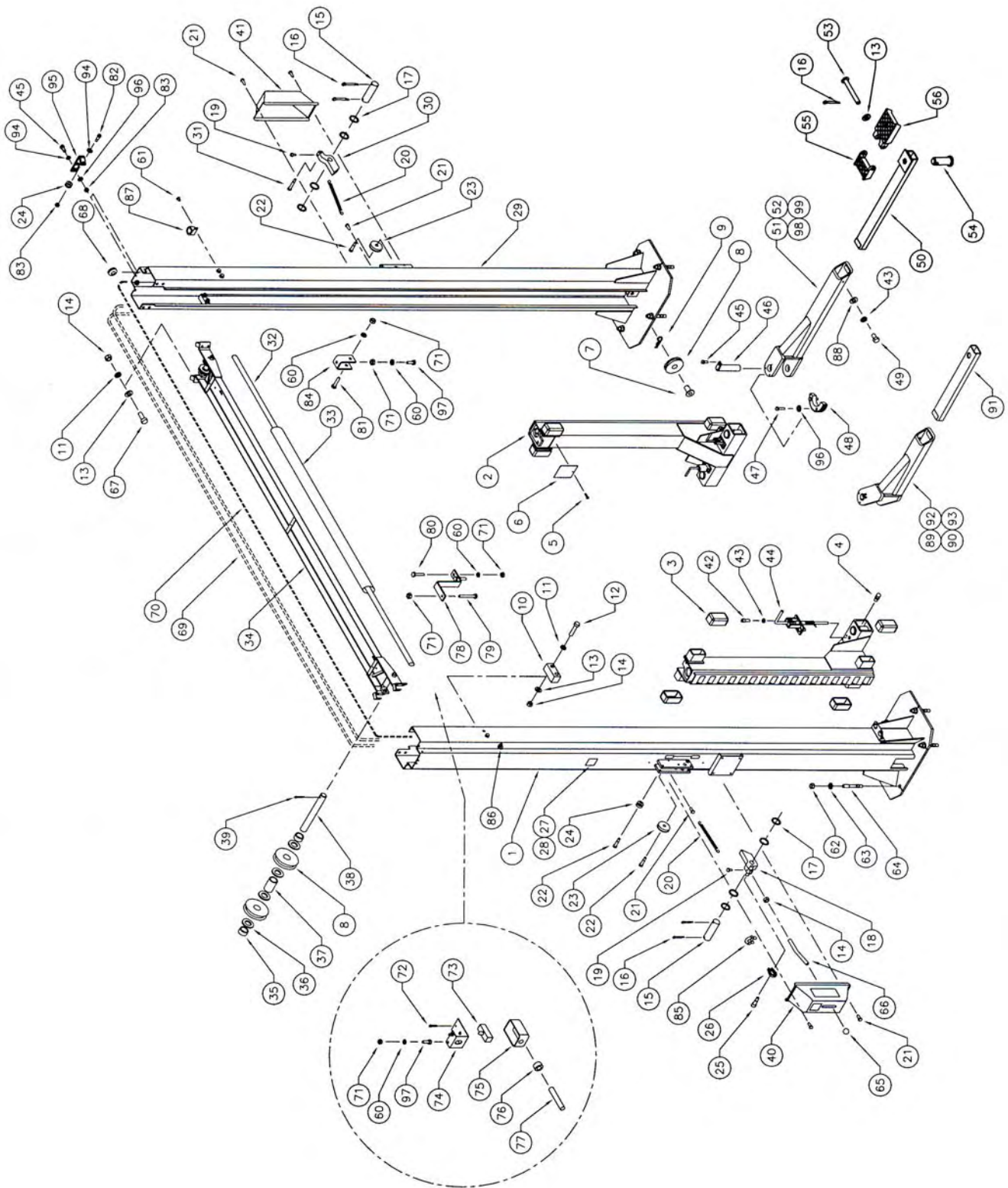

8.2 LIFT ASSEMBLY PARTS LIST

ITEM	QTY	DESCRIPTION	PART #
1	1	TOWER WELDMENT, POWER SIDE	4-0767
2	2	CARRIAGE WELDMENT	4-0766
3	8	GLIDE BEARING	2-0772
4	4	GREASE NIPPLE	6-0000
7	2	PIN, CABLE EQUALIZATION	1-1887
8	6	2-POST PULLEY	1-1898
9	2	HITCH PIN, 1/8" DIA	6-1841
11	8	LOCKWASHER, 1/2"ID	6-0059
13	12	FLAT WASHER, 1/2"ID SAE	6-0248
14	13	HEX NUT, 1/2"-13UNC	6-0035
15	2	SAFETY PIN	1-0938
16	8	COTTER PIN, 1/8"DIA. x 1"LG.	6-0267
17	8	FLAT WASHER, 5/16"ID x 1"OD x 1/16"THK.	6-0808
18	1	SAFETY DOG WELDMENT, POWER SIDE	2-1901
19	4	SELF TAPPING SCREW, #10 X 3/8" LG.	6-0169
20	2	SAFETY SPRING	1-1115
21	6	SELF TAPPING SCREW, #12 x 1/2"LG.	6-1134
22	3	SHOULDER BOLT, 3/8"DIA. x 1"LG.	6-0206
23	2	SAFETY PULLEY	1-0415
24	3	SAFETY CABLE PULLEY	1-1116
25	1	SHOULDER BOLT, 3/8"x 1 1/2" LG.	6-0801
26	1	THIMBLE, 5/32"	6-2074
27	1	CAPACITY DECAL	6-1767
28	1	SERIAL PLATE	6-1111
29	1	TOWER WELDMENT, SLAVE SIDE	4-0768
30	1	SAFETY DOG, SLAVE SIDE	2-0872
31	1	SHOULDER BOLT, 3/8"DIA. x 1 1/2"LG.	6-0801
32	1	ACTUATOR BAR	1-1380
33	1	FOAM GUARD	6-1404
34	1	CROSSMEMBER WELDMENT	3-0694
35	4	CROSSMEMBER PULLEY PIPE, 1/2"LG.	1-1623
36	8	FLAT WASHER, 3/4"ID	6-0738
37	2	CROSSMEMBER PULLEY PIPE, 1 3/4"LG.	1-1626
38	2	CROSSMEMBER PULLEY SHAFT	2-1252
39	2	COTTER PIN, 1/8"DIA. x 1 1/2"LG.	6-0978
40	1	SAFETY COVER cw/DECALS, POWER SIDE	0-0204
41	1	SAFETY COVER cw/DECALS, SLAVE SIDE	0-0203
42	8	SOCKET HEAD CAP SCREW, 3/8" X 1" LG.	6-2048
43	12	LOCKWASHER, 3/8" ID	6-0058
44	4	ARM RESTRAINT ASSEMBLY	1-2038
45	8	HEX BOLT, 5/16"-18UNC x 3/4" LG.	6-0423
46	4	ARM PIN	2-1594
47	4	HEX BOLT, 5/16"-18UNC x 1 1/4" LG.	6-2059
48	4	ARM RESTRAINT GEAR	1-2618
49	4	HEX BOLT, 3/8UNCx3/4"LG.	6-0030
50	2	INNER ARM WELDMENT (LONG)	3-0762

ITEM	QTY	DESCRIPTION	PART #
51	1	OUTER ARM WELDMENT (LONG – L.S.)	3-0835
52	1	LOCKING ARM ASS'Y cw/ARM RESTRAINT PIN (LONG – L.S.)	4-0939-6
53	4	CENTER PIN	1-1099
54	4	ADAPTER PIN	1-1979
55	4	LOW POSITION ADAPTER	3-0583
56	4	HIGH POSITION ADAPTER	3-0582
60	6	LOCKWASHER, 1/4" ID	6-0056
61	6	ROUND HEAD SCREW, 1/4"-20UNC x 3/8" LG.	6-1353
62	10	HEX NUT, 3/4"-10UNC	6-0737
63	10	FLAT WASHER, 3/4"ID	6-0738
64	10	WEDGE ANCHOR, 3/4"-10UNC x 5 1/2"LG.	6-1379
65	1	PLASTIC KNOB	6-1135
66	1	SAFETY RELEASE HANDLE	1-1113
67	8	HEX BOLT, 1/2"-13UNC x 1 1/4" LG.	6-0046
68	3	RUBBER GROMMET	6-1507
69	2	EQUALIZING CABLE	1-1786
70	1	SAFETY RELEASE CABLE	1-2058
71	7	HEX HD. NUT 1/4"NC	6-0032
72	2	6/32 SCREW (ELECTRICAL BOX)	6-1466
73	1	MICROSWITCH	6-0916
74	1	LIMIT SWITCH MTG. BRACKET	2-1143
75	1	ELECTRICAL UTILITY BOX	6-1403
76	1	CABLE CONNECTOR	6-1133
77	1	ELEC. CABLE 12/3 x 117"LG.	6-1173
78	1	ACTUATOR EXTENSION	1-1379
79	1	HEX HD. BOLT 1/4"NC x 2"LG.	6-0741
80	2	HEX HD. BOLT 1/4"NC x 1 1/4"LG.	6-0027
81	1	HEX HD. BOLT 1/4"NC x 1 1/2"LG.	6-0205
82	2	SHOULDER BOLT, 3/8"DIA. x 5/8"LG.	6-0069
83	6	HEX NUT, 5/16"-18UNC	6-0294
84	1	ACTUATOR MTG. BRACKET	1-1378
85	2	WIRE ROPE CLIP, 1/16"	6-2060
86	3	ELECTRICAL CABLE CLIP, 5/8" ID	6-1759
87	6	TUBE CLAMP, 1/2"	6-0536
88	4	FLATWASHER, 3/8"ID SAE	6-0062
89	1	OUTER ARM WELDMENT (SHORT – R.S.)	3-0836
90	1	OUTER ARM WELDMENT (SHORT – L.S.)	3-0837
91	2	INNER ARM WELDMENT (SHORT)	3-0763
92	1	LOCKING ARM ASS'Y cw/ARM RESTRAINT PIN (SHORT– R.S.)	4-0940-6
93	1	LOCKING ARM ASS'Y cw/ARM RESTRAINT PIN (SHORT – L.S.)	4-0941-6
94	6	LOCKWASHER, 5/16"ID	6-0296
95	2	PULLEY BRACKET	2-1477
96	12	FLATWASHER, 5/16"ID	6-0295
97	4	HEX SOCKET CAP SCREW 1/4" UNC X 3/4" LG.	6-1744
98	1	OUTER ARM WELDMENT (LONG – R.S.)	3-0834
99	1	LOCKING ARM ASS'Y c/w ARM RESTRAINT PIN (LONG – R.S.)	4-0938-6

8.3 HYDRAULIC SYSTEM

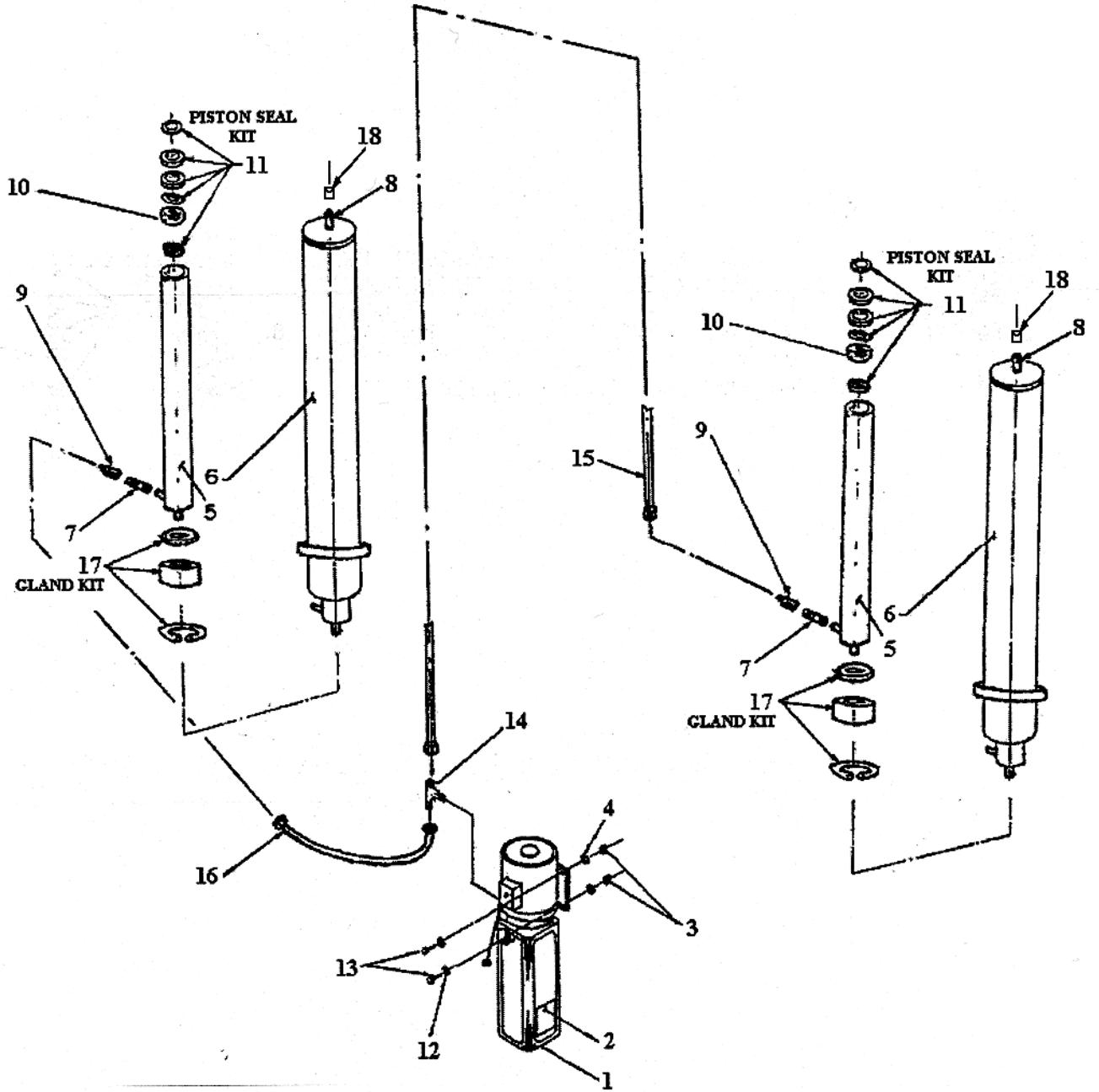

8.4 HYDRAULIC SYSTEM PARTS LIST

ITEM	QTY	DESCRIPTION	PART #
1	1	POWER PACK	6-2055
2	1	"LIFT OPERATION" DECAL	6-2094
3	4	HEX NUT, 5/16"-18UNC	6-0294
4	4	LOCK WASHER, 5/16" I.D.	6-0674
5	2	PISTON ROD	2-1254
6	2	CYLINDER TUBE	2-125501
7	2	MALE NIPPLE, 1/4" NPT	6-2095
8	2	1/8" NPT TO 1/4" JIC	6-0280
9	2	FLOW CONTROL	6-1510
10	2	PISTON	1-1467
11	2	PISTON SEAL KIT	0-0337
12	4	FLAT WASHER, 5/16" I.D.	6-0295
13	4	HEX BOLT, 5/16"-18UNCx1" LG.	6-0293
14	1	BRANCH TEE	6-1506
15	1	HYDRAULIC HOSE (LONG)	2-1486
16	1	HYDRAULIC HOSE (SHORT)	2-1230
17	2	GLAND KIT	0-0338
18	2	1/4" JIC CAP	6-1884
	*	CYLINDER ASSEMBLY (NOT INCL. FLOW CONTROL)	3-062101

8.5 POWER PACK: #6-2055 (AB-1381) 208-230V/1PH/60Hz

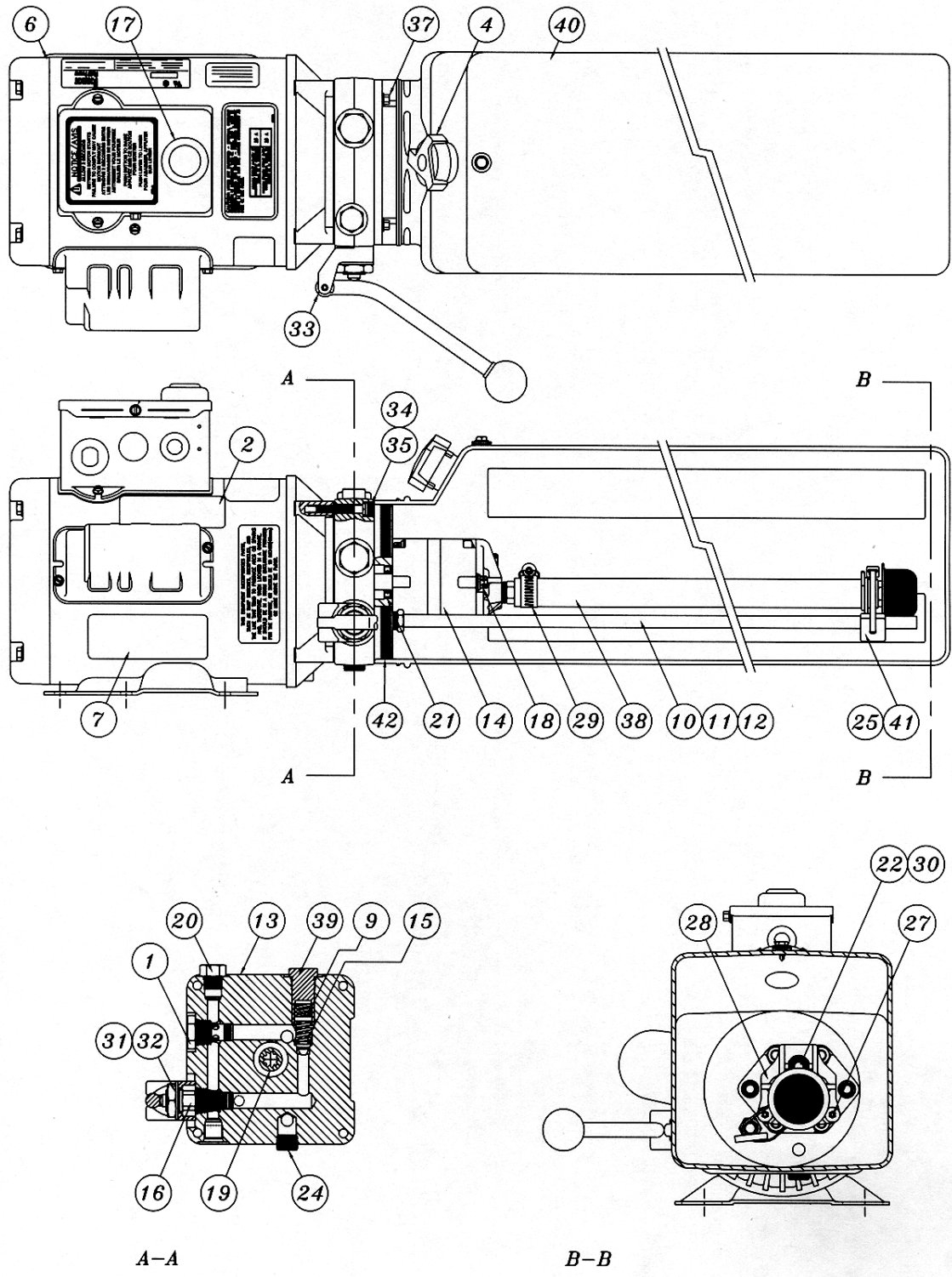

8.6 POWER PACK PARTS LIST: #6-2055 (AB-1381) 208-230V/1PH/60Hz

ITEM	QTY.	DESCRIPTION	PART #
1	1	VALVE CARTRIDGE CHECK	6-1087
2	1	LABEL INSTALLATION AUTOHOIST	6-2136
4	1	BREATHER CAP & BLADDER	6-1376
6	1	MOTOR AC 208-230V. 2HP/1PH/60Hz, BLK	6-2474
7	1	LABEL WARNING AUTOHOIST	6-2149
9	1	SPRING 0.480" x 0.063" x 0.42" COMP	6-2151
10	1	RETURN HOSE 3/8" OD x 21.5"	6-2152
11	1	COMPRESSION TUBE NUT	6-2153
12	1	COMPRESSION TUBE SLEEVE	6-2154
13	1	ENDHEAD UNIVERSAL AUTOHOIST	6-2155
14	1	PUMPASSY 2.5 CC/REV. SHORT SPLINE	6-1958
15	1	RELIEF ASSEMBLY FIXED 190 BAR	6-1319
16	1	VALVE CARTRIDGE RELEASE MANUAL	6-0880
17	1	WIRING ASSEMBLY AC 1PH FENNER	6-2473
18	2	BOLT 5/16"-24 x 3.00" TORX G8	6-1090
19	1	COUPLING SAE 9T-20/40 1.260"	6-0774
20	1	PLUMBING PLUG 9/16" SAE	6-2157
21	1	SEAL SHAFT 0.500" x 1.00" x 0.25"	6-2158
22	1	WASHER 0.338" x 0.625" x 0.060" STEEL	6-2159
24	1	PLUMBING PLUG 3/8" NPT	6-2161
25	1	PLUMBING MAGNET	6-2162
27	2	SCREW TAPTITE M6 x 1.0 12MM TORX	6-2164
28	1	COVER ASSY SUCTION	6-2165
29	1	PLUMBING CLAMP HOSE ADJ. INLET	6-2166
30	1	BOLT 5/16"-18 x 1.00" SHCS	6-1392
31	1	NUT 3/4"-16 x 1" HEX x 0.250" STEEL	6-2167
32	1	WASHER 3/4" INT. TOOTH LOCK	6-2168
33	1	BRACKET - HANDLE ASSY REL BLACK	6-0776
34	4	BOLT M6 x 1.0 35MM SOC HD	6-2169
35	4	WASHER 1/4" LOCK HI-COLLAR	6-2170
37	4	BOLT #12-24 x 0.50' HEX WSHRHD	6-1091
38	1	PLUMBING ASSY INLET 17.24 (3)	6-0786
39	1	RELIEF VALVE CAP ASSEMBLY	6-1089
40	1	TANK PLASTIC 6.7 OS 22.50" BLK	6-1399
41	1	CABLE TIE 8" LONG WHITE	6-1846
42	1	O-RING 2-348 BUNA	6-0875

8.7 LIFT MAINTENANCE GUIDELINES – CABLE EQUALIZATION

Two Post Lifts

Safety Instructions

Read operating and safety manuals before using any lift
Do not operate a lift that has been damaged or is in disrepair
Proper inspection and maintenance is necessary for safe operation

General

Check all hydraulic lines and fittings for pinch points , damage , cracks or leaks
Check all electrical wiring for pinch points , cracks or damage
Check all moving parts for uneven or excessive wear
Repair or replace all damaged , defective , worn or broken components immediately

Cable Equalized Two Post Lift

- clean and re-grease slide block channels inside of both columns every two months
- grease arm pins every two months
- check and lubricate safety dogs and safety cable adjustment every two months
- dismantle , clean and lubricate arm restraints every two months
- dismantle and clean inner arms every four months
- lubricate cable pulleys every four months
- check equalizing cables and adjust every four months or as required
- change hydraulic oil every two years
- periodically check anchor bolts and re-torque if required

Hydraulically Equalized Two Post Lift

- check and adjust hydraulic level weekly or as required
- clean and re-grease slide block channels inside of both columns every two months
- grease arm pins every two months
- check and lubricate safety dogs and safety cable adjustment every two months
- dismantle , clean and lubricate arm restraints every two months
- dismantle and clean inner arms every four months
- change hydraulic fluid every two years
- periodically check anchor bolts and re-torque if required

Lubrication : Where grease is required > multi-purpose lithium grease
Where lubricating oil is required > multi-purpose SAE 30 lubricating oil
Where hydraulic oil is required > ISO 32 10W - non detergent hydraulic oil